

# Installation Instructions for Trilock Eclipse

Suits 35mm to 45mm door thickness

## Step 1.

- Fold template where indicated.
- Position template on door edge at desired lock / latch height.
- Firmly hold template and mark latch height and 2 off 60mm holes centres.
- Measure door thickness and mark centre on 'latch height' marking.
- Drill 22mm (7/8") latch hole.

- **Note:** it is important to drill this hole squarely.
- Drill pilot holes [suggested size 3mm (1/8")]. Then enlarge holes to 60mm, drilling from both sides of the door.

In particular, ensure the 60mm dia. holes through door face are drilled only to this size, otherwise correct functioning may be impeded – refer template.

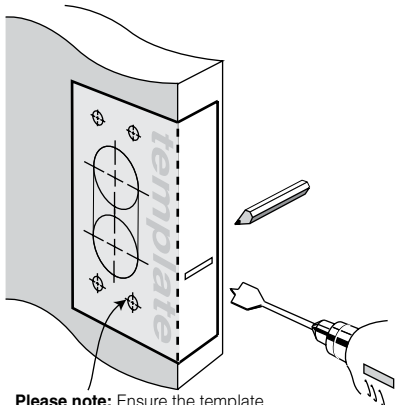

**Please note:** Ensure the template position and orientation is as shown, incorrect installation voids warranty.

## Step 2.

- Mark vertical lines between two holes as per illustration.
- Cut along marked lines

Mark vertical lines between holes as shown. Cut along vertical lines

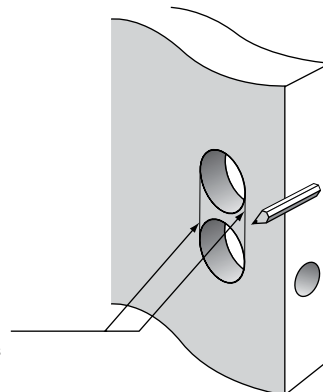

## Step 3.

- Mark and chisel latch faceplate to a recess of 2.5mm. Use latch carrier as a template.
- Insert lock body into 60mm (2 3/8") slot.
- Insert latch carrier through 22mm (7/8") hole into lock body assembly and tighten with 2 screws.

**Ensure T-shaped hole at rear of latch carrier is upright!**

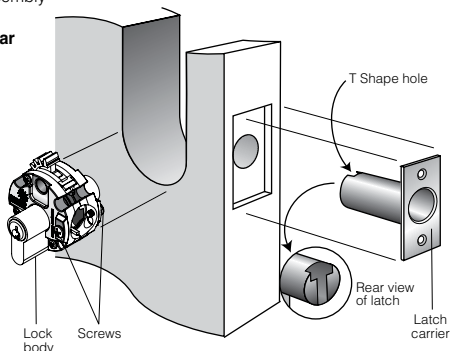

## Step 4.

- Insert the latch through the slot in the carrier until it can go no further.
- Insert the key and turn to retract the latch bolt.
- Pre-drill wood screw holes with suitable drill size.
- Install plastic faceplate shim and faceplate, then screw into position.

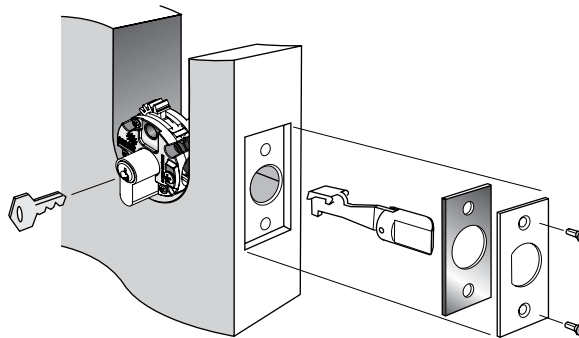

## Step 4a

### Trilock Latch Bolt re-handing.

- Check that tapered side of the Latch bolt faces towards the door jamb.
- It may be necessary to unclip the rear arm & rotate bolt 180°
- This is achieved by following steps:

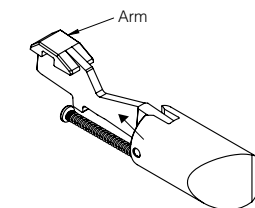

1. Remove Latch bolt assembly from carrier

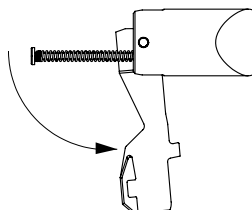

2. Rotate arm down wards

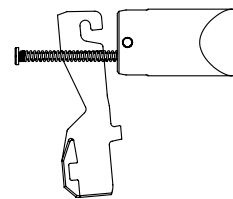

3. Unclip arm from latch bolt

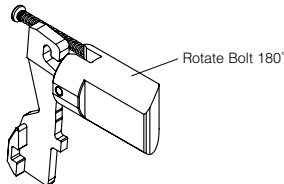

4. Rotate Bolt 180°

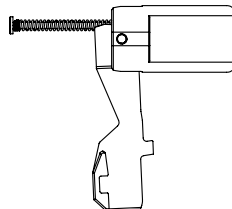

5. Re-attach arm to latch bolt

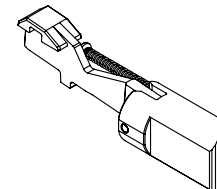

6. Rotate arm up wards & fit back into carrier

**NOTE:**

- carefully follow these instructions when installing.
- do not overtighten screws.
- use of power driver is not recommended.
- fully remove the Trilock prior to painting the door to avoid harming the product's finish.

*Gainsborough*  
ENTER WITH STYLE™

3 IN 1 FUNCTION  
**TRILOCK™**  
DEADBOLT | LOCKSET | PASSAGE SET  
ECLIPSE SERIES

# Installation Instructions for Trilock Eclipse

Suits 35mm to 45mm door thickness

## Step 5

- Remove perforated cut-out from card-board template and place over lock body, making sure template is square to door edge.
- While holding template firmly in position, mark remaining 4 holes, as indicated on both sides of the door (reversing template as required).
- Drill pilot holes from both sides of the door [suggested size 3mm (1/8")] then enlarge, again from both sides of the door, to sizes indicated on template, otherwise correct functioning may be impeded – refer template.

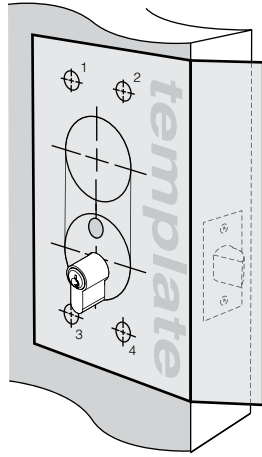

## Step 6

### To rehand internal lever & set lever operation (if required).

- Hold Trilock faceplate up to door to check lever orientation.
- To rehand lever, if required, insert flat blade screwdriver under handing-plate and twist.
- Rotate lever 180° toward top of faceplate, as shown, until it clicks into place.

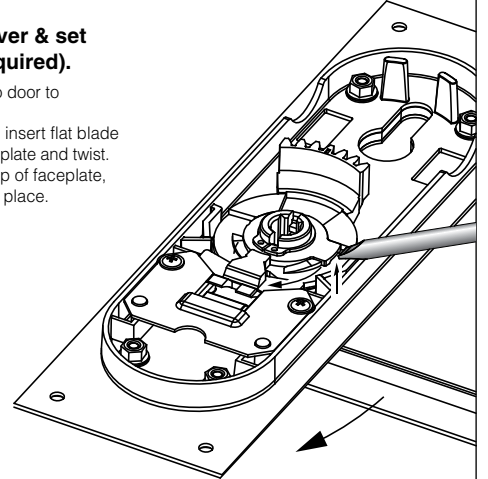

## Step 7

### To rehand external lever & set lever operation (if required).

- To rehand remove the stop screw and rotate the lever 180° and refit the stop screw.

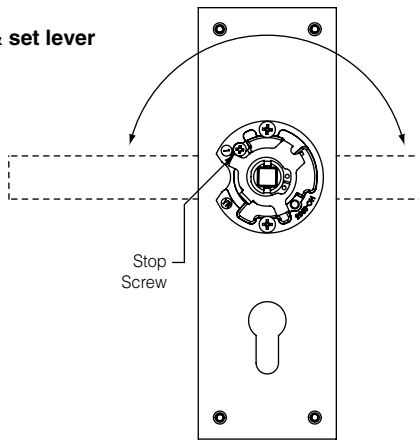

## Step 8.

- Install posts to Trilock external faceplate (this is the faceplate **without** the rectangular snib push-button).

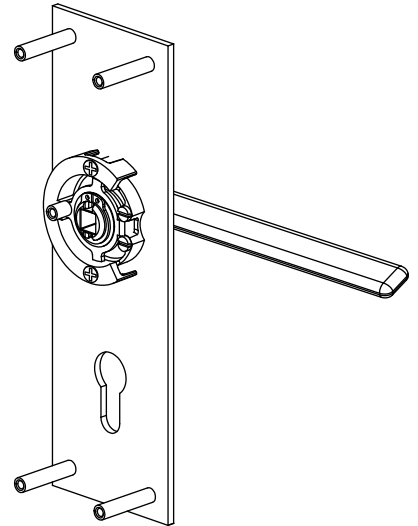

## Step 9

- Mount the Inside face plate so that mark on large gear engages with mark on lock bodygear

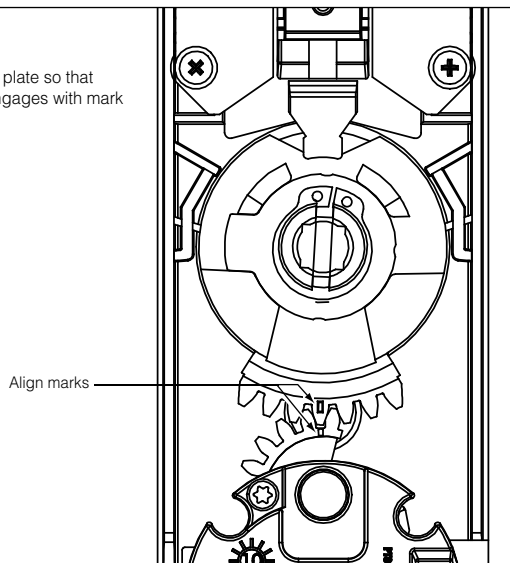

**NOTE:**

- carefully follow these instructions when installing.
- do not overtighten screws.
- use of power driver is not recommended.
- fully remove the Trilock prior to painting the door to avoid harming the product's finish.

*Gainsborough*  
ENTER WITH STYLE™

3 IN 1 FUNCTION  
**TRILOCK™**  
DEADBOLT | LOCKSET | PASSAGE SET  
ECLIPSE SERIES

# Installation Instructions for Trilock Eclipse

Suits 35mm to 45mm door thickness

## Step 10

- Insert spring and snib rotor in the square hole of the internal lever.
- Position snib rotor so one notch faces up and the other notch points to the latch side.
- Mount outside faceplate to outside of the door, and align the two making sure the snib rotor engages with the external lever.
- Fit mounting screws from inside and tighten into threaded posts.

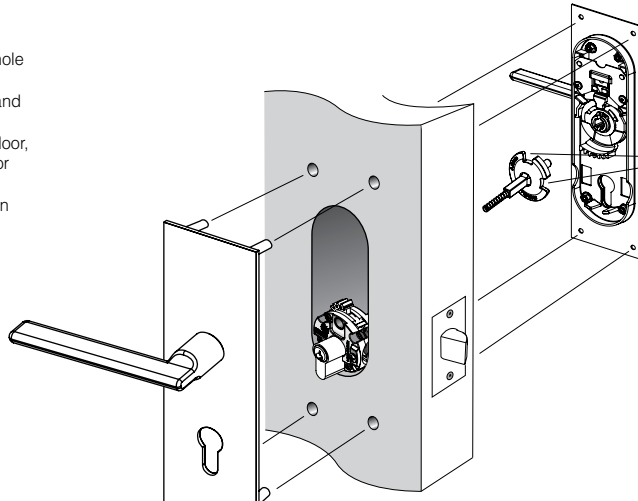

**Note:** Position Snib Rotor so one notch faces up & the other notch points to the door edge.

**NOTE:** Test all functions for smooth operation.

## Step 11

- For single cylinder applications install internal turnbutton now by tightening grub-screw onto protruding shaft.

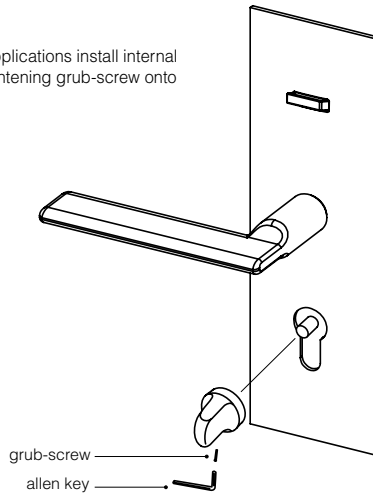

## Step 12

**All door seals must be fitted prior to fitting strike plate.**

- Position the door so that the centrepoint of the strike plate can be marked on door frame.

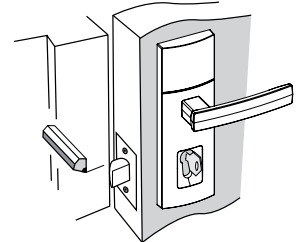
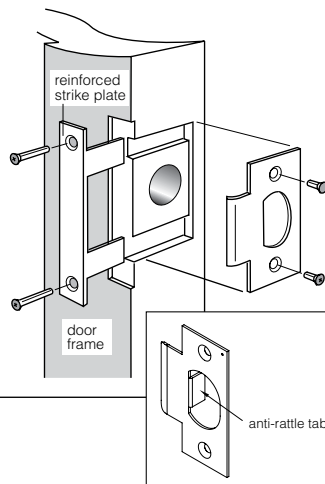

- Mark and drill a 25mm (1") hole to a depth of 25mm (1"), at a corresponding height to the bolt.
- Mark and chisel recesses for strike plate and optional reinforced strike plate.
- Screw into position using 4 wood screws as supplied.

**Note:** 2 larger screws should be used on reinforced strike plate as illustrated.

### Door Adjustment

- 1 When door is closed using finger pressure, ensure bolt is latching into strike plate.
- 2 If door is rattling when in latched position. Open door, remove strike plate & adjust anti-rattle tab & refit strike plate to door frame. Repeat check 1.

**NOTE:**

- carefully follow these instructions when installing.
- do not overtighten screws.
- use of power driver is not recommended.
- fully remove the Trilock prior to painting the door to avoid harming the product's finish.

*Gainsborough*  
ENTER WITH STYLE™

3 IN 1 FUNCTION  
**TRILOCK™**  
DEADBOLT | LOCKSET | PASSAGE SET  
ECLIPSE SERIES

# Installation Instructions for Trilock Eclipse

Suits 35mm to 45mm door thickness

## Exploded Diagram

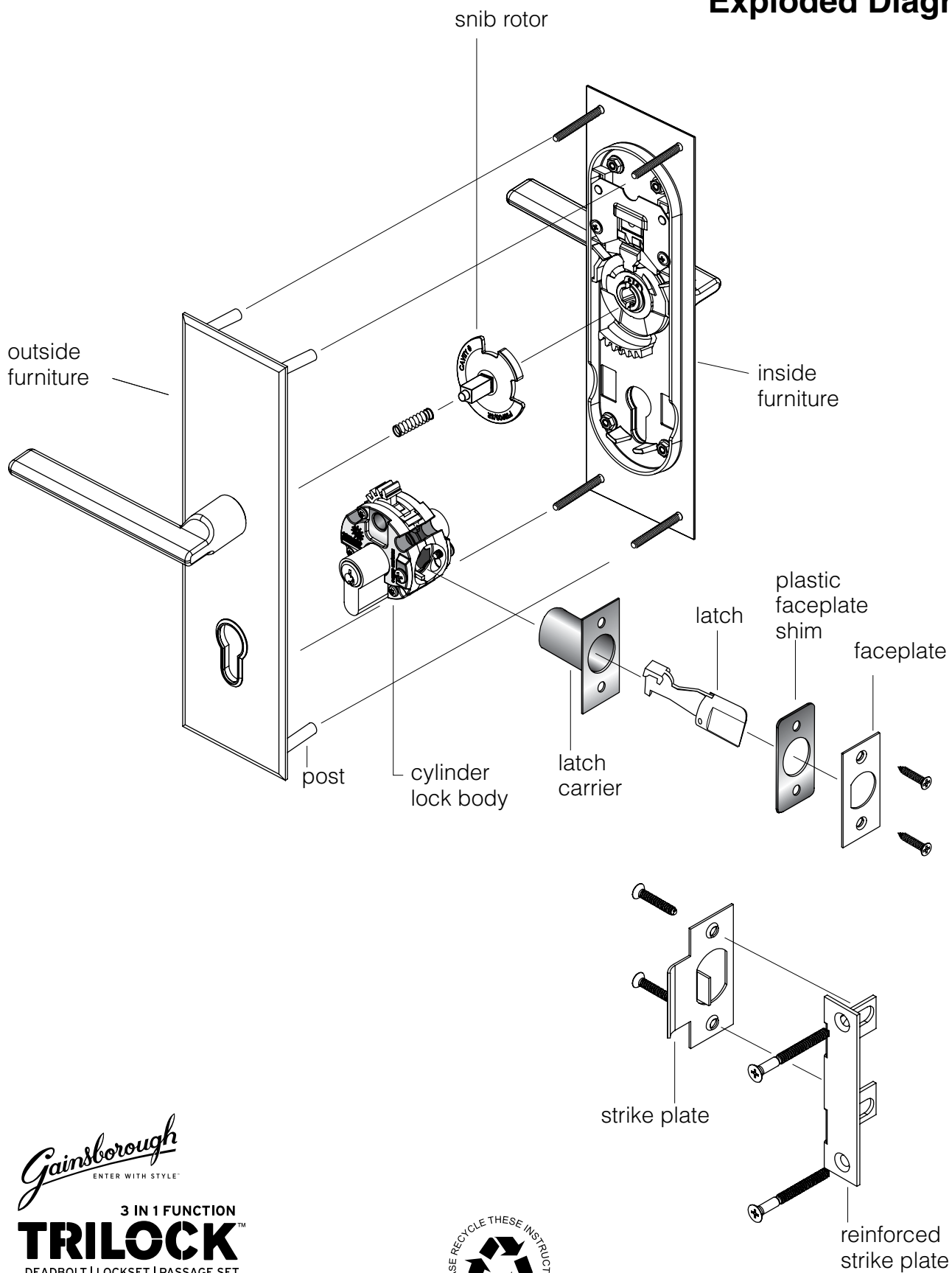

*Gainsborough*  
ENTER WITH STYLE™

**3 IN 1 FUNCTION**  
**TRILOCK™**  
DEADBOLT | LOCKSET | PASSAGE SET  
**ECLIPSE SERIES**

