

Step 1.

- Fold template where indicated.
- Position template on door edge at desired latch height (suggested height is 970mm from floor).
- Firmly hold template and mark latch height and handle fixing holes at 60mm backset (refer template).
- Measure door thickness and mark centre.
- Drill 25mm (1") latch hole.
- Note:** it is important to drill this hole squarely.
- Drill one 50mm (2") hole or one 54mm (2 1/8") hole through door face at required backset as marked on template.

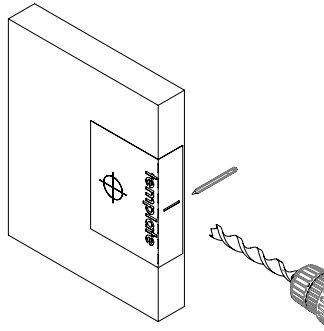

Step 2.

- Mark and chisel door edge for latch face plate to a recess of 2mm or until flush with door. Use latch face plate as a template.
- Pre-drill wood screw holes with suitable drill size.
- Insert latch and fasten with wood screws provided.

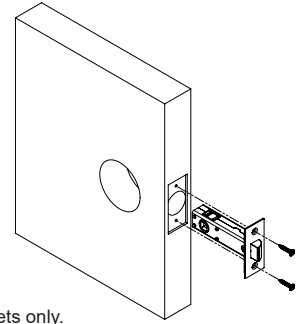

Latch is included with selected passage sets only.
Latches can be ordered separately.

Step 3.

- Attach QuickFix furniture with preinstalled studs and screws.

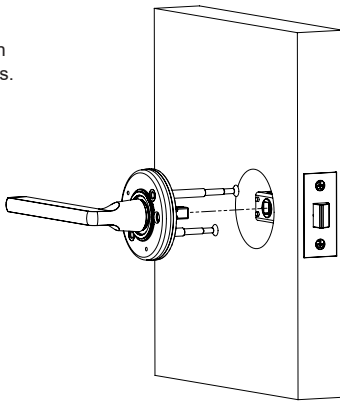

Step 4.

- Install furniture.

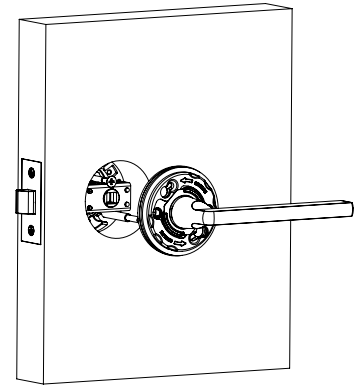

NOTE: Carefully follow these instructions when installing.
Screws to be hand tightened to a recommended 2.5Nm torque.

Continued on next page



Mark centre-line
of latch hole

Mark centre-line
of latch hole

FOLD HERE

Fit here on door edge

Fit here on door edge

54mm (2 1/8") hole
or drill 50mm (2")
hole – refer Step 1.

BACKSET 60mm (2 3/8")

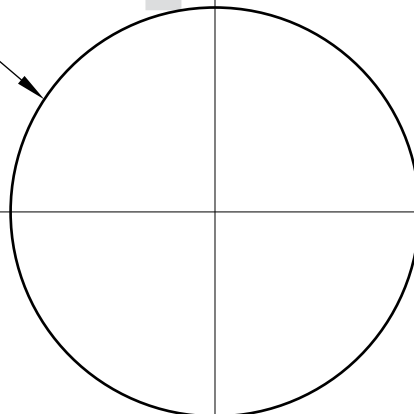

ALLEGION

Allegion (Australia) Pty Ltd
Freephone 1800 098 094
Email info.au@allegion.com
www.allegion.com.au



Step 5.

- Rotate bezel to lock in place and tighten screws.

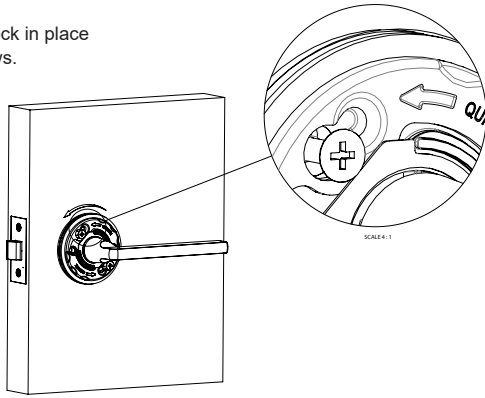

Step 6.

- Measure Ø8mm either side of centre mark, drill Ø25x15mm hole.
- Use strike as a guide to mark and chisel recess, allowing space behind strike plate for the dust box.
- Insert dust box, drill holes and screw strike in place.

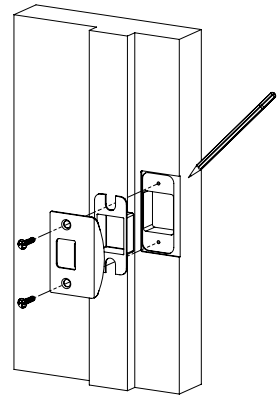

Step 7.

- Fit rose cover.

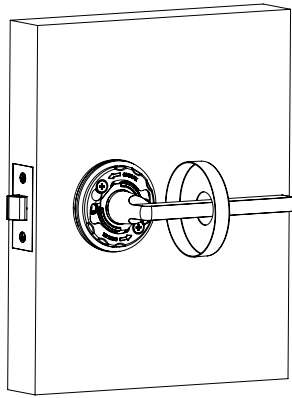

Step 8. (For privacy function only)

- Fit privacy pin.

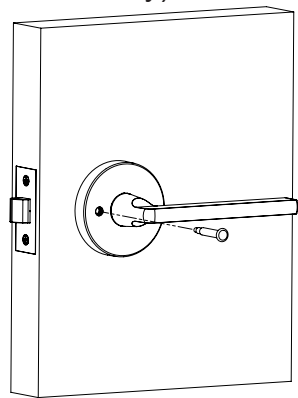

NOTE: Carefully follow these instructions when installing. Screws to be hand tightened to a recommended 2.5Nm torque.



FOLD HERE

Mark centre-line of latch hole

Mark centre-line of latch hole

Fit here on door edge

Fit here on door edge

54mm (2 1/8") hole or drill 50mm (2") hole – refer Step 1.

BACKSET 60mm (2 3/8")

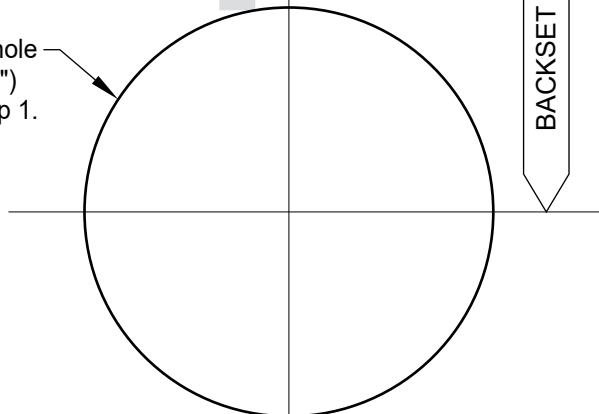

ALLEGION

Allegion (Australia) Pty Ltd
Freephone 1800 098 094
Email info.au@allegion.com
www.allegion.com.au

