

# Installation Instructions for 1946 Single Cylinder & 1951 Double Cylinder Deadbolts

## Step 1.

- Fold template where indicated.
- Position template on door edge at desired latch height.
- Firmly hold template and mark latch height on door edge and 54mm (2 1/8") lock body hole centre.
- Measure door thickness and mark centre.
- Drill 22mm (7/8") latch hole through door edge.

**Note:** it is important to drill this hole squarely.  
• Drill pilot hole for lock body [suggested size 3mm (1/8")]. Then enlarge hole to 54mm (2 1/8"), drilling from both sides of the door.

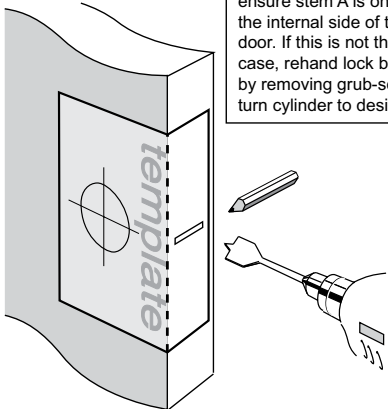

**Please Note:**

for a single cylinder deadbolt (ie. with internal turnbutton) ensure stem A is on the internal side of the door. If this is not the case, rehand lock body by removing grub-screw with allen key provided, turn cylinder to desired direction and re-fasten.

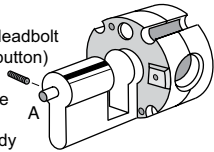

## Step 2.

- Mark and chisel latch faceplate until flush with door edge. Use latch carrier as a template.
- Insert lock body into 54mm (2 1/8") hole.
- Insert bolt carrier through 22mm (7/8") hole into lock body assembly and fix with 2 screws. Ensure T-shape at rear of bolt carrier is upright.

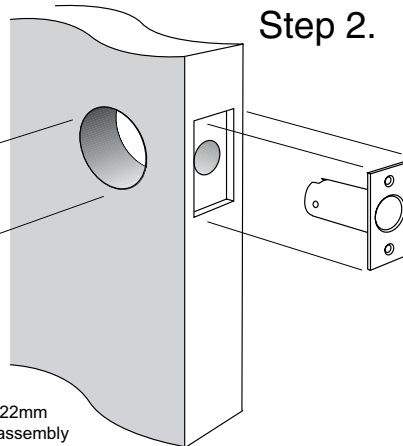

## Step 3.

- Insert key and rotate towards edge of the door.
- Insert bolt until stop and rotate key away from edge of the door.
- If bolt does not operate properly repeat above steps.

- Pre-drill wood screw holes with suitable drill size.
- Install plastic faceplate shim and faceplate, then screw into position.

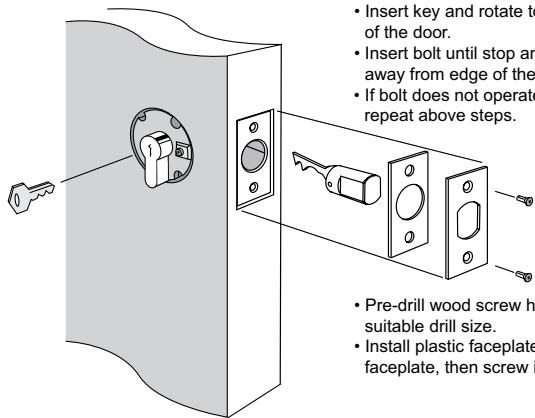

## Step 4.

- Fit suitable length screws through diagonal holes on internal rosette to threaded posts on external escutcheon.
- Note:** do not overtighten screws.
- Insert key and rotate to check lock function. Please note that deadbolt requires 180° key rotation to achieve deadlocking.
- If bolt does not operate properly repeat step 3.

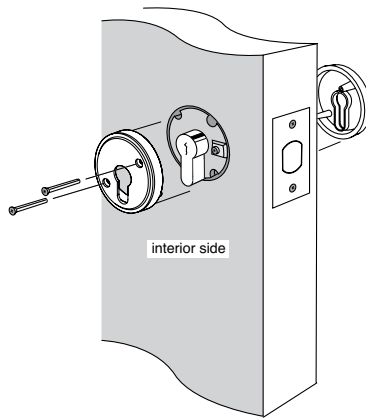

**NOTE:** Carefully follow these instructions when installing. Screws to be tightened to a recommended 2.5Nm torque max.



Mark centre-line of latch hole

Mark centre-line of latch hole

FOLD HERE

Fit here on door edge

Fit here on door edge

54mm (2 1/8") hole

BACKSET 60mm (2 3/8")



Gainsborough Hardware Industries Limited,  
Melbourne, Australia. A.B.N. 25 004 792 269  
[www.gainsboroughhardware.com.au](http://www.gainsboroughhardware.com.au)

PAIT 162  
JAN '12

Installation template  
for 1946 single cylinder  
and 1951 double cylinder  
deadbolts



# Installation Instructions for 1946 Single Cylinder & 1951 Double Cylinder Deadbolts

### Step 5.

- Fit caps over escutcheons.
- For single cylinder applications install internal turnbutton now by tightening grub-screw on to protruding shaft.

### Step 6.

- Extend bolt out of door and position the door so that the centrepoint of the strike plate can be marked on door frame.
- Mark and drill a 25mm (1") hole to a depth of 25mm (1"), at a corresponding height to the bolt.
- Mark and chisel recesses for strike plate and optional reinforced strike plate.
- Screw into position using 4 wood screws as supplied.

**Note:** 2 larger screws should be used on reinforced strike plate as illustrated.

