

Installation instructions for 110 Series Privacy Leversets

on 63mm Round Rosettes with adjustable 60mm or 70mm backsets

Step 1.

- Fold template where indicated.
- Position template on door edge at desired latch height.
- Firmly hold template and mark latch height and handle fixing holes at required backset (refer template).
- Measure door thickness and mark centre.
- Drill 25mm (1") latch hole.

Note: it is important to drill this hole squarely.

- Drill one 50mm (2") hole or one 54mm (2 1/8") hole through door face at required backset as marked on template.

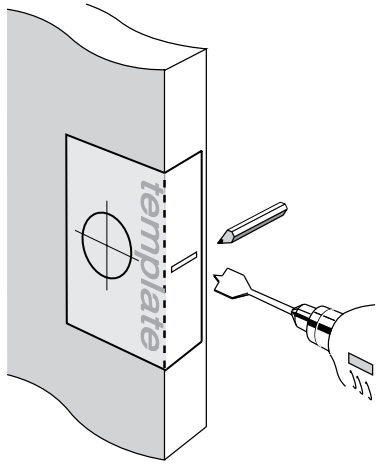

Step 2.

- Mark and chisel door edge for latch face plate to a recess of 2mm or until flush with door. Use latch face plate as a template.
- Pre-drill wood screw holes with suitable drill size.
- Insert latch and fasten with wood screws provided.

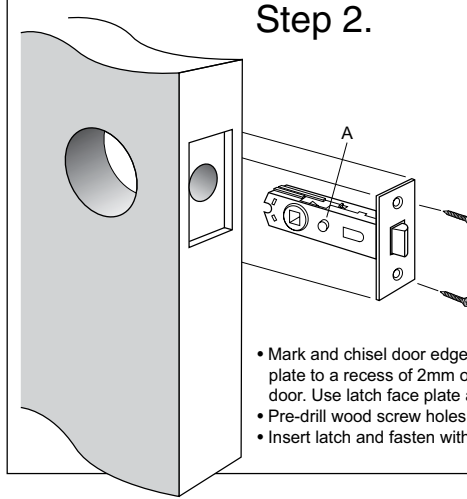

Step 3.

Install lever assemblies to door

- Insert square drive spindle (1) through latch in door.
- Put "O" ring (6) onto groove in spindle from other side of door to that which the spindle entered.
- Identify which side of the door each lever assembly will need to be located in order to allow both levers to move in a downward motion once installed.
- Remove rosette covers (2) from both lever assemblies.
- Place one lever assembly (3) onto the square drive spindle.
- Place other lever assembly (4) into position, locating it onto the other end of spindle.
- Fasten both lever assemblies together with screws provided (5): Use long screws for thick doors and short screws for thin doors.
- Each under-rose features a countersunk hole and a threaded hole. Install one screw from either side, through the countersunk hole and into the threaded hole of the opposite under-rose. Then tighten the screw head on each side.
- Tighten the grub screws (7) at base of levers on both sides with the hexagonal key (8) provided.
- Re-apply rosette covers (2) to both under-roses by pushing the covers over the rubber rings until flush with door. Ensure small notch in cover aligns with matching profile in under-rose, allowing clear access to privacy button/emergency release hole (10).
- Install the privacy button (9) through the privacy button/emergency release hole (10) on the internal side of the door and screw tight.

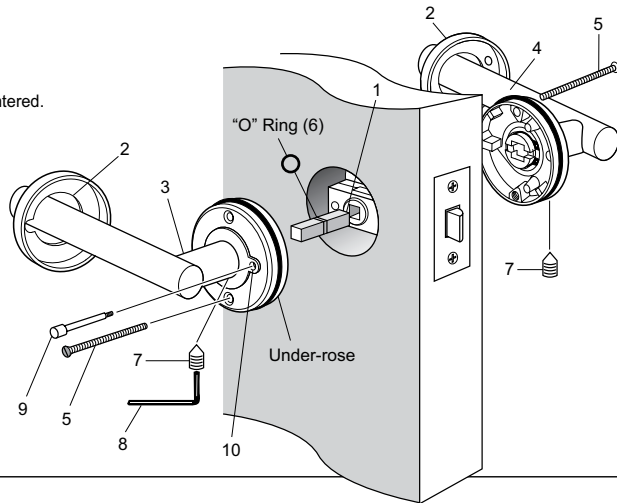

NOTE: Carefully follow these instructions when installing. Screws to be tightened to a recommended 2.5Nm torque.



Important Note

Only drill holes applicable to 60mm backset.
70mm backset privacy latch available separately – see your stockist.

Mark centre-line of latch hole

Mark centre-line of latch hole

FOLD HERE

Fit here on door edge

Fit here on door edge

54mm (2 1/8") hole or drill 50mm (2") hole – refer Step 1.

BACKSET 60mm (2 3/8")

BACKSET 70mm (2 3/4")

Gainsborough
ENTER WITH STYLE™

Gainsborough Hardware Industries Limited,
Melbourne, Australia. A.B.N. 25 004 792 269
www.gainsboroughhardware.com.au

Suits doors 32mm (1 1/4") to 45mm (1 3/4") thick.

Installation template for privacy applications

