

# Installation Instructions for Trilock Contemporary

These instructions apply to both Lever and Knob versions

## Step 1.

- Fold template where indicated.
- Position template on door edge at desired lock / latch height.
- Firmly hold template and mark latch height and 54mm (2 1/8") lock body hole centre.
- Measure door thickness and mark centre on 'latch height' marking.
- Drill 22mm (7/8") latch hole. NOTE: it is important to drill this hole squarely.
- Drill pilot hole for lock body [suggested size 3mm (1/8")]. Then enlarge hole to 54mm (2 1/8"), drilling from both sides of the door.

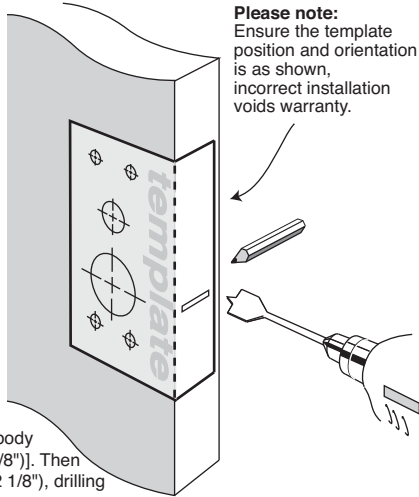

**Please note:** Ensure the template position and orientation is as shown, incorrect installation voids warranty.

## Step 2.

- Remove latch carrier screws **E** (one from either side).
- Insert and rotate key towards latch carrier.
- Pull latch carrier and bolt sub-assembly away from lock body.

- Mark and chisel latch faceplate to a recess of 3.5mm. Use latch carrier as a template.
- Insert lock body into 54mm (2 1/8") hole.
- Insert latch carrier through 22mm (7/8") hole into lock body assembly and fix with 2 screws. **Ensure T-shaped hole at rear of latch carrier is upright!**

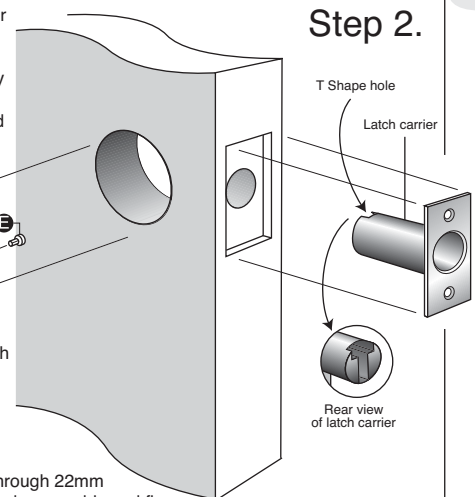

T Shape hole

Latch carrier

Rear view of latch carrier

## Step 3.

- Check that tapered side of the latch bolt faces towards the door jamb, it may be necessary to un-clip the rear arm **A** of the latch bolt and rotate 180°, this is achieved by pushing the bolt **B** and arm **A** together and un-clipping.

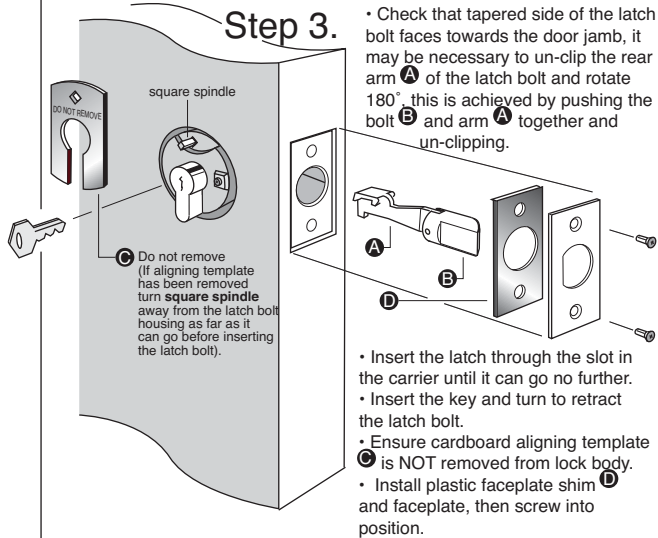

Do not remove (if aligning template has been removed turn square spindle away from the latch bolt housing as far as it can go before inserting the latch bolt).

- Insert the latch through the slot in the carrier until it can go no further.
- Insert the key and turn to retract the latch bolt.
- Ensure cardboard aligning template **C** is NOT removed from lock body.
- Install plastic faceplate shim **D** and faceplate, then screw into position.

## Step 4.

- Remove cut-outs from cardboard template and place over lock body, making sure template is square to door edge.
- While holding template firmly in position, mark remaining 5 holes as indicated on both sides of the door (reversing template as required).
- Drill pilot holes from both sides of the door [suggested size 3mm (1/8")] then enlarge, again from both sides of the door, to sizes indicated on template.
- In particular, ensure the 32mm (1 1/4") dia. hole through door face (located above lock body hole) is drilled only to this size, otherwise correct functioning may be impeded—refer template.

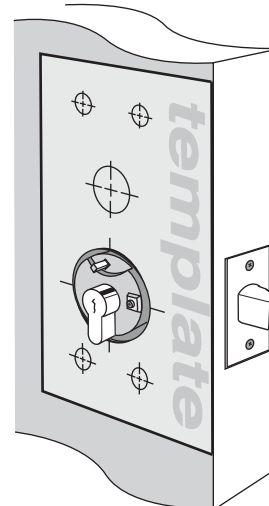

## handing information

## Step 5.

- Hold Trilock faceplate up to door to check lever orientation (this will need to be done on both levers).
- To rehand lever, if required, insert flat blade screwdriver under handing-plate and twist.
- Rotate lever 180° toward bottom of faceplate, as shown, until it clicks into place.

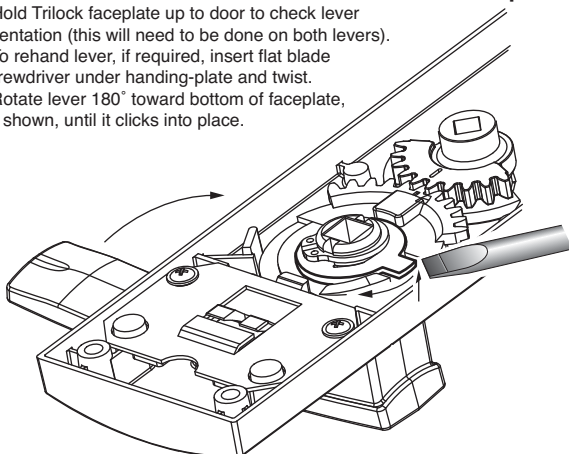

**NOTE:** The step is applicable to leverset only.

## Step 6.

- Install posts to Trilock external faceplate (this is the faceplate **without** the rectangular snib push-button).

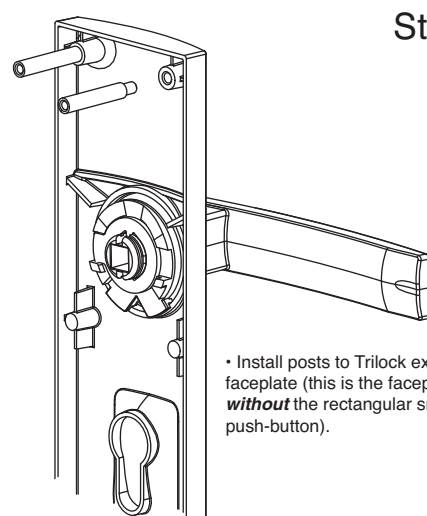

Suits 33mm to 45mm door thicknesses

- NOTE:**
- carefully follow these instructions when installing.
  - do not overtighten screws.
  - use of power driver is not recommended.
  - screws to be tightened to a recommended 2.5Nm torque.
  - fully remove the Trilock prior to painting the door to avoid harming the product's finish.

3 IN 1 FUNCTION  
**TRILOCK™**  
 DEADBOLT | LOCKSET | PASSAGE SET  
 CONTEMPORARY SERIES

# Installation Instructions for Trilock Contemporary

These instructions apply to both Lever and Knob versions

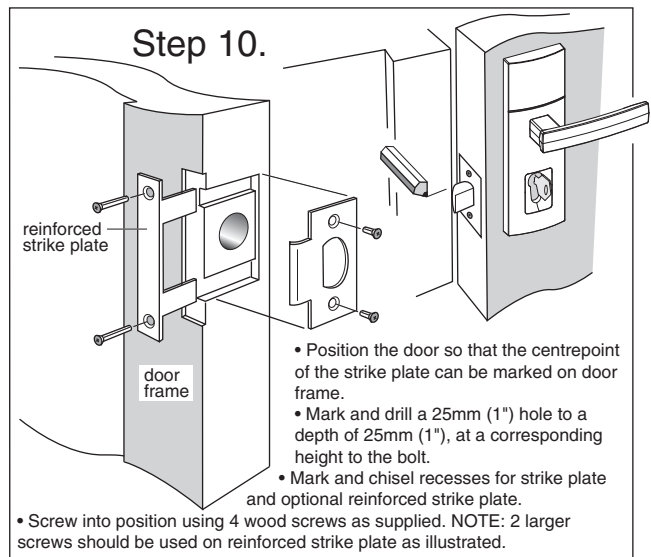
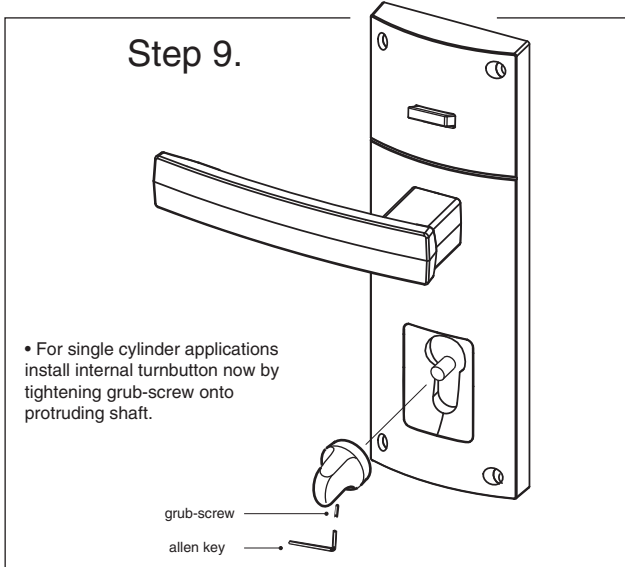
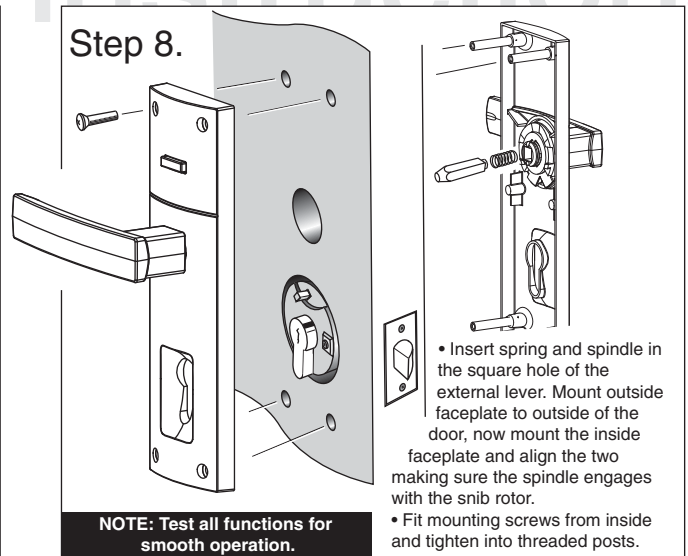
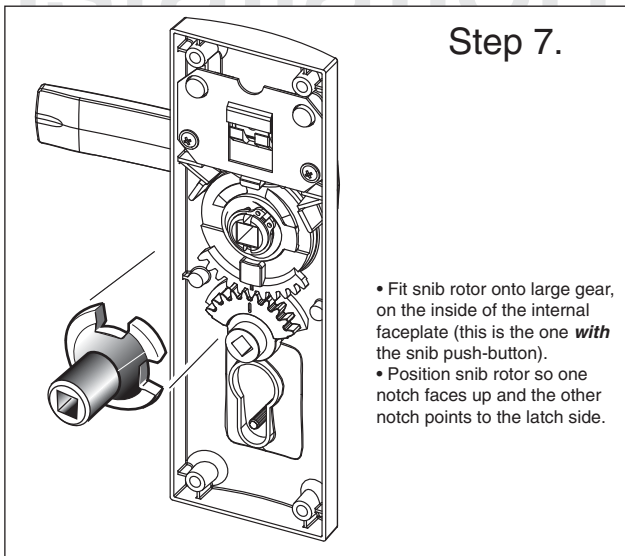

Australian Patents: App. 662657  
Plus other foreign patents

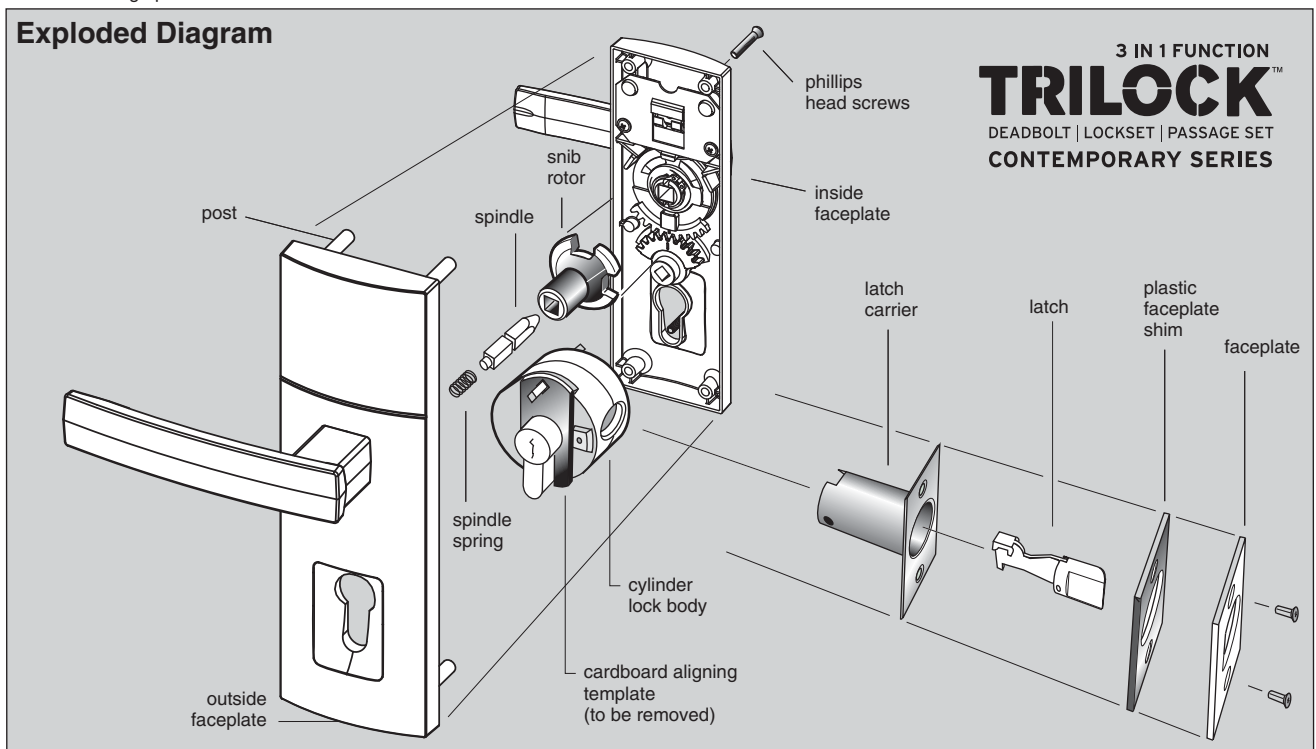

Designed and Assembled in Australia by Gainsborough Hardware Industries Limited,  
Melbourne, Australia. A.B.N. 25 004 792 269

[www.gainsboroughhardware.com.au](http://www.gainsboroughhardware.com.au)