

Installation Instructions for 846 & 851 Deadbolts

Step 1.

- Fold template where indicated.
- Position template on door edge at desired latch height.
- Firmly hold template and mark latch height on door edge and 54mm (2 1/8") lock body hole centre.
- Measure door thickness and mark centre.
- Drill 22mm (7/8") latch hole through door edge.

Note: it is important to drill this hole squarely.

- Drill pilot hole for lock body [suggested size 3mm (1/8")]. Then enlarge hole to 54mm (2 1/8"), drilling from both sides of the door

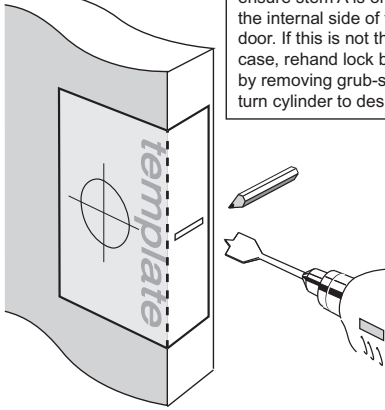

Please Note:

for a single cylinder deadbolt (ie. with internal turnbutton) ensure stem A is on the internal side of the door. If this is not the case, rehand lock body by removing grub-screw with allen key provided, turn cylinder to desired direction and re-fasten.

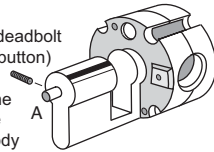

Step 2.

- Mark and chisel latch faceplate to a recess of 3.5mm. Use latch carrier as a template.
- Insert lock body into 54mm (2 1/8") hole.
- Insert bolt carrier through 22mm (7/8") hole into lock body assembly and fix with 2 screws. Ensure T-shape at rear of bolt carrier is upright!

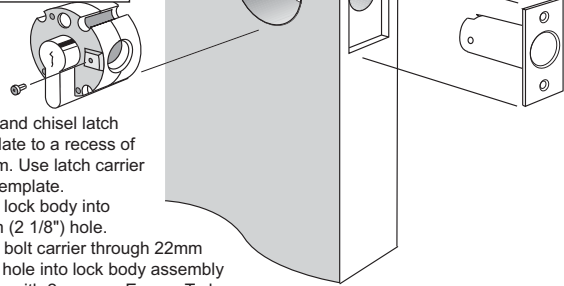

Step 3.

- Insert key and rotate towards edge of the door.
- Insert bolt until stop and rotate key away from edge of the door.
- If bolt does not operate properly repeat above steps.
- Install plastic faceplate shim and faceplate, then screw into position.

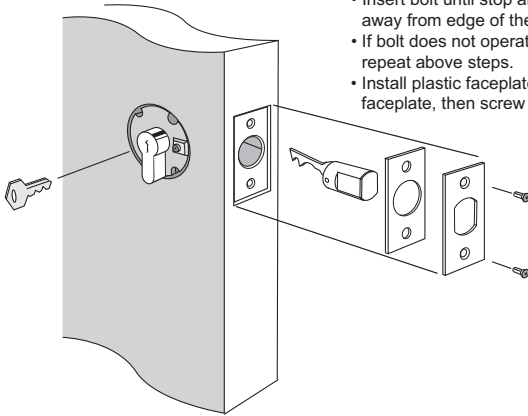

Step 4.

- Screw external escutcheon to snap fix assembly.
- Note:** do not overtighten screws. Ensure snap fix assembly is located on the interior side of the door.
- Insert key and rotate to check lock function. Please note that deadbolt requires 180 degree key rotation to achieve deadlocking.
- If bolt does not operate properly repeat step 3.

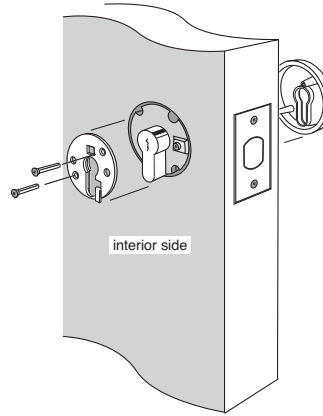

NOTE: Carefully follow these instructions when installing. Screws to be tightened to a recommended 2.5Nm torque.



FOLD HERE

Mark centre-line of latch hole

Mark centre-line of latch hole

Fit here on door edge

54mm (2 1/8") hole

BACKSET 60mm (2 3/8")

Fit here on door edge

Gainsborough[®]

Gainsborough Hardware Industries Limited,
Melbourne, Australia. A.B.N. 25 004 792 269
www.gainsboroughhardware.com.au

PAIT044
MAY '09

Installation template for
851 double cylinder and
846 single cylinder deadbolts

Installation Instructions for 846 & 851 Deadbolts

Step 5.

- Snap fix internal escutcheon to the door.
- for single cylinder applications install internal tumbbutton now by tightening grub-screw on to protruding shaft.

interior side

Step 6.

- extend bolt out of door and position the door so that the centrepoint of the strike plate can be marked on door frame.
- mark and drill a 25mm (1") hole to a depth of 25mm (1"), at a corresponding height to the bolt.
- mark and chisel recesses for strike plate and optional reinforced strike plate.
- screw into position using 4 wood screws as supplied.

Note: 2 larger screws should be used on reinforced strike plate as illustrated.

door frame

