

Installation Instructions for Trilock Traditional – Single Cylinder Leverset

Step 1.

- Fold template where indicated.
- Position template on door edge at desired lock / latch height.
- Firmly hold template and mark latch height and 54mm (2 1/8") lock body hole centre.
- Measure door thickness and mark centre on 'latch height' marking.
- Drill 22mm (7/8") latch hole. NOTE: it is important to drill this hole squarely.
- Drill pilot hole for lock body [suggested size 3mm (1/8")]. Then enlarge hole to 54mm (2 1/8"), drilling from both sides of the door.

Please note:
For this single cylinder Trilock version, the turnbutton stem (A) should be on the internal side of the door. If this is not the case, please re-hand the lock body. To re-hand: remove the grub screw with allen key provided, remove and turn the cylinder to desired direction and re-install. Re-fasten grub screw with allen key.

Please note:
Ensure the template position and orientation is as shown, incorrect installation voids warranty.

Step 2.

- Mark and chisel latch faceplate to a recess of 3.5mm. Use latch carrier as a template.
- Insert lock body into 54mm (2 1/8") hole.
- Insert latch carrier through 22mm (7/8") hole into lock body assembly and fix with 2 screws. **Ensure T-shaped hole at rear of latch carrier is upright!**

Step 3.

- Check that tapered side of the latch bolt faces towards the door jamb, it may be necessary to un-clip the rear arm **A** of the latch bolt and rotate 180°, this is achieved by pushing the bolt **B** and arm **A** together and un-clipping.
- Insert the latch through the slot in the carrier until it can go no further.
- Insert the key on external side of the door and turn to retract the latch bolt.
- Ensure cardboard aligning template **C** is NOT removed from lock body.
- Install plastic faceplate shim **D** and faceplate, then screw into position.

Do not remove (If aligning template has been removed turn square spindle away from the door edge as far as it can go before inserting the latch bolt).

Step 4.

- Remove cut-outs from cardboard template and place over lock body, making sure template is square to door edge.
- While holding template firmly in position, mark remaining 5 holes as indicated on both sides of the door (reversing template as required).
- Drill pilot holes from both sides of the door [suggested size 3mm (1/8")] then enlarge, again from both sides of the door, to sizes indicated on template.
- In particular, ensure the 32mm (1 1/4") dia. hole through door face (located above lock body hole) is drilled only to this size, otherwise correct functioning may be impeded—refer template.

Step 5.

- Hold Trilock faceplate up to door to check lever orientation (this will need to be done on both levers).
- To rehand lever, if required, insert flat blade screwdriver under handing-plate and twist.
- Rotate lever 180° toward bottom of faceplate, as shown, until it clicks into place.

handing information

Step 6.

- Install blind screws and brass posts to Trilock external faceplate (this is the faceplate *without* the round snib push-button).

Suits 33mm to 45mm door thicknesses

NOTE:

- carefully follow these instructions when installing.
- do not overtighten screws.
- use of power driver is not recommended.
- screws to be tightened to a recommended 2.5Nm torque.
- fully remove the Trilock prior to painting the door to avoid harming the product's finish.



Installation Instructions for Trilock Traditional – Single Cylinder Lever

Leverset

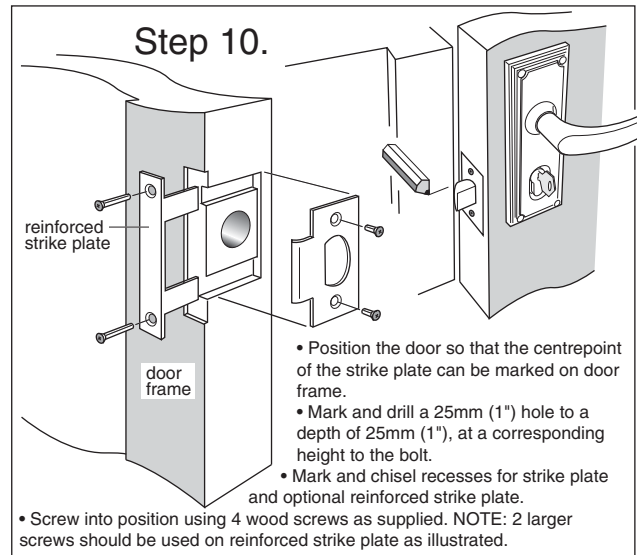
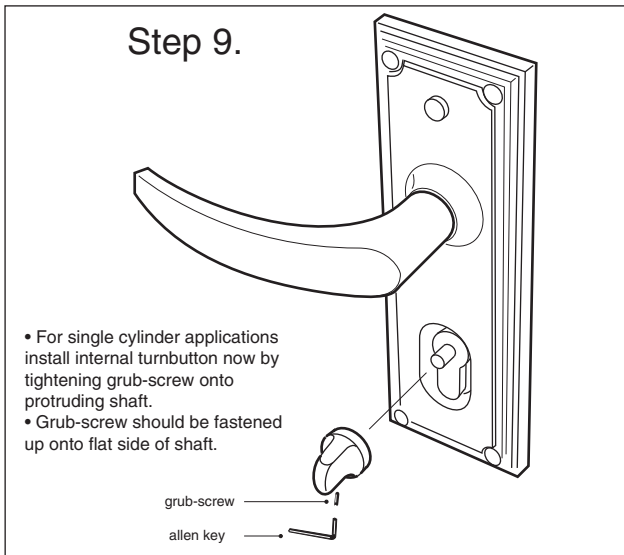
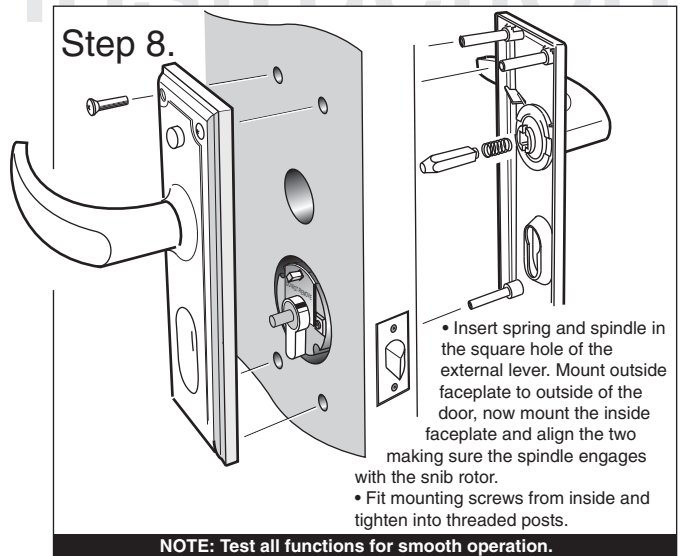
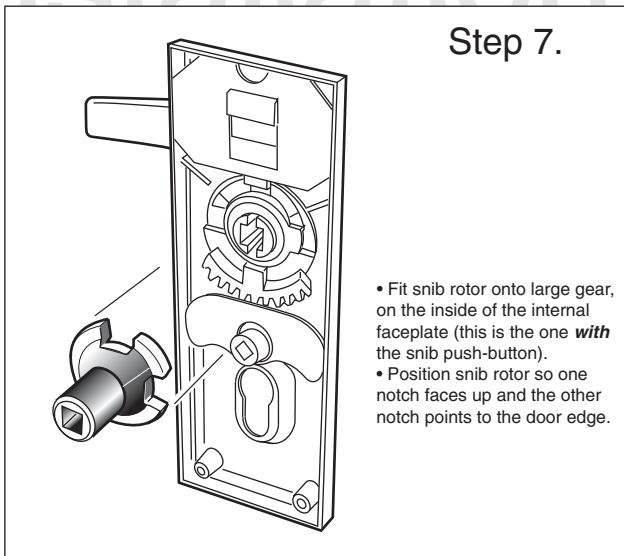

Australian Patents: App. 662657
Plus other foreign patents

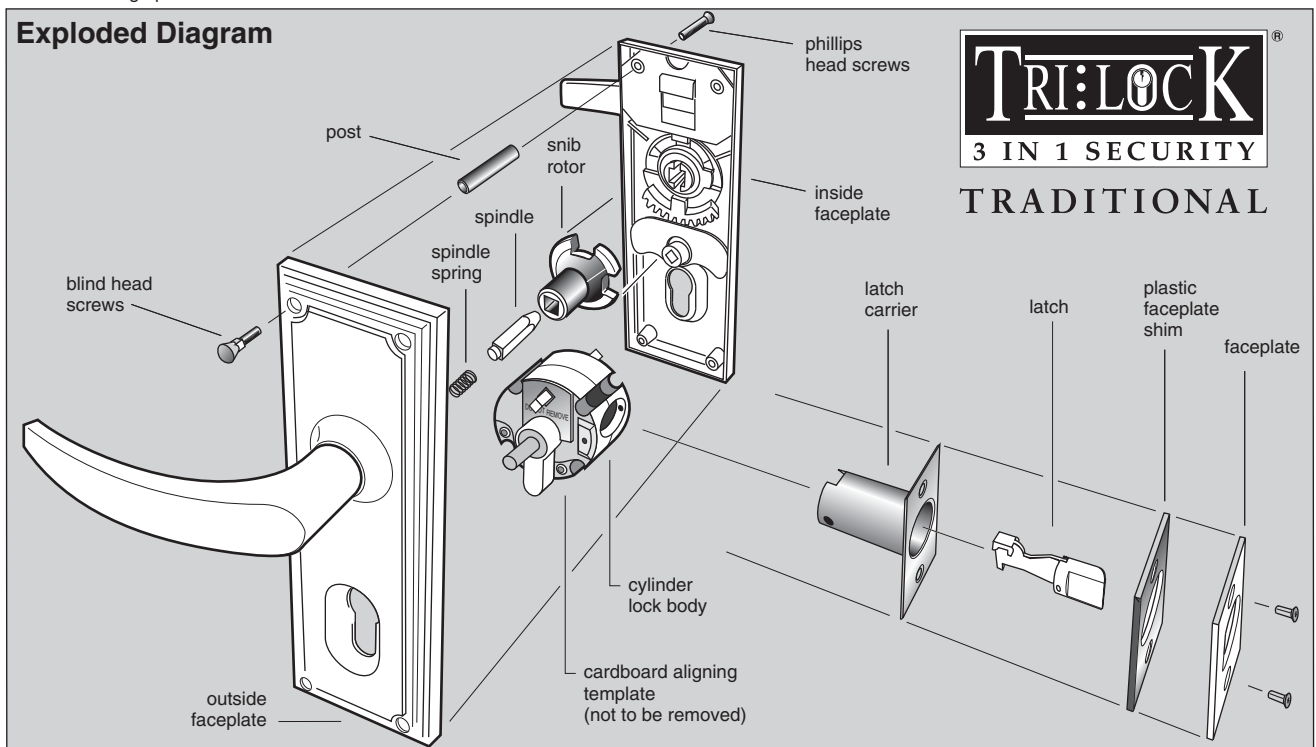

Designed and Manufactured in Australia by Gainsborough Hardware Industries Limited,
Melbourne, Australia. A.B.N. 25 004 792 269

www.gainsboroughhardware.com.au