

3 IN 1 FUNCTION

TRILOCK
DEADBOLT | LOCKSET | PASSAGE SET
OMNI SERIES

**TRILOCK OMNI DUMMY TEMPLATE
AND INSTALLATION INSTRUCTIONS**

Installation template for Gainsborough Trilock Omni Dummy
Suits 35mm to 45mm door thicknesses

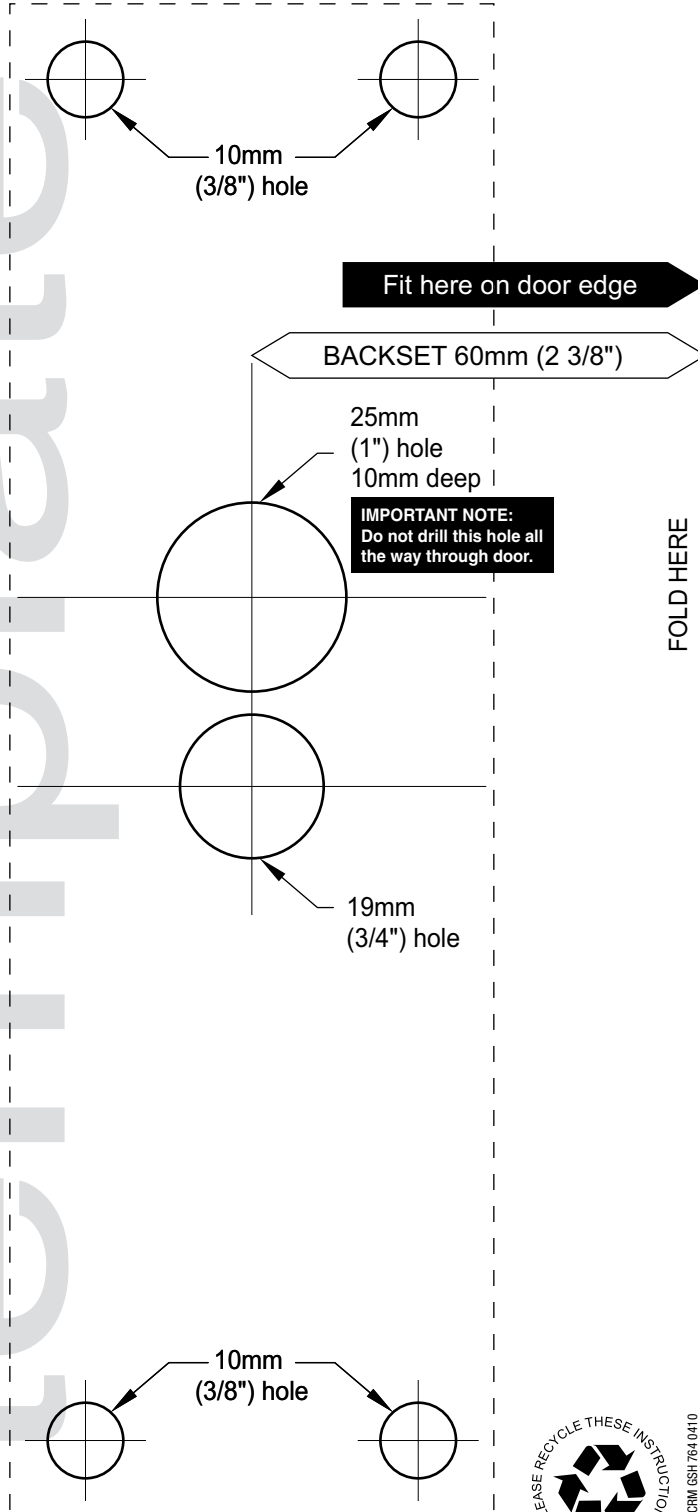

- Fold template where indicated.
- Position template on door edge at desired height. (Generally to line up with operating Trilock on opposite door)
- Firmly hold template to door and mark the four hole centres as indicated.
- Prepare and drill holes. Firstly, start with the 19mm (3/4") hole (suggest to drill pilot holes first at 6mm, 1/4") then enlarge to the correct size of 19mm, (3/4"). It is also recommended that you drill from both sides of the door.
- Prepare and drill the 4 x 10mm holes (suggest to drill pilot holes first at 3mm, 1/8") then enlarge to the correct size of 10mm, 3/8". It is also recommended that you drill from both sides of the door.
- Prepare and drill the 25mm hole 10mm deep from inside door face **(Do not drill all the way through the door)**.
- To rehand internal lever & set lever operation, hold Trilock faceplate up to door to check lever orientation, insert flat blade screwdriver under handing-plate and twist. Rotate lever 180° toward bottom of faceplate, as shown, until it clicks into place.
- Install posts to external faceplate (this is the flat plate with the vertical handle).
- Insert dummy plug into the inside of the internal plate/ escutcheon before affixing faceplates to door. (To help hold dummy plug in position, apply a strip of adhesive tape if required.)
- Mount the outside faceplate to door.
- Align the inside faceplate to door and fit mounting screws and tighten into threaded posts.
- To fix single pull handle (note: suitable for solid doors only), check that the outside faceplate is lined up straight and square with the door. Once the desired position of the outside faceplate has been confirmed, mark the centre of the hole at the top of the faceplate and proceed to drill a suitable hole.
- Note: When drilling the hole drill to a suitable depth **ONLY** to accommodate the coach screw **(Do not drill all the way through the door)**.
- On the side requiring the pull handle, hold the optional rectangular plastic washer centred over the hole against the door surface. Then hold the threaded bush onto the stainless steel, ensuring the larger section of the bush, as marked 'A' in illustration, is facing the door.
- Then, from the same side, install the 1/4" diameter coach screw through the threaded bush and optional plastic washer (if used) and into the door. Tighten coach screw securely with spanner.
- Place the two pull handle supports at each end of the pull handle over the top of the two bushes that are fitted to the door and faceplate. Line up the pull handle so that it is lined up straight and square. Insert the grub screws and tighten with allen key provided.

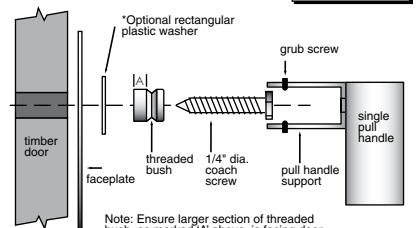
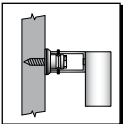
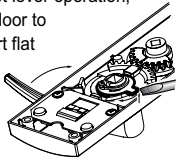

Note: Ensure larger section of threaded bush, as marked 'A' above, is facing door



3 IN 1 FUNCTION
TRILOCK
DEADBOLT | LOCKSET | PASSAGE SET
OMNI SERIES

**TRILOCK OMNI DUMMY TEMPLATE
AND INSTALLATION INSTRUCTIONS**

- Fold template where indicated.
- Position template on door edge at desired height.
(Generally to line up with operating Trilock on opposite door)
- Firmly hold template to door and mark the four hole centres as indicated.
- Prepare and drill holes. Firstly, start with the 19mm (3/4") hole (suggest to drill pilot holes first at 6mm, 1/4") then enlarge to the correct size of 19mm, (3/4"). It is also recommended that you drill from both sides of the door.
- Prepare and drill the 4 x 10mm holes (suggest to drill pilot holes first at 3mm, 1/8") then enlarge to the correct size of 10mm, 3/8". It is also recommended that you drill from both sides of the door.
- Prepare and drill the 25mm hole 10mm deep from inside door face
(Do not drill all the way through the door).

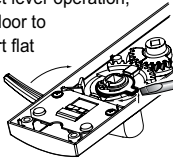

- To rehand internal lever & set lever operation, hold Trilock faceplate up to door to check lever orientation, insert flat blade screwdriver under handing-plate and twist. Rotate lever 180° toward bottom of faceplate, as shown, until it clicks into place.
- Install posts to external faceplate (this is the flat plate with the vertical handle).
- Insert dummy plug into the inside of the internal plate/ escutcheon before affixing faceplates to door. (To help hold dummy plug in position, apply a strip of adhesive tape if required.)
- Mount the outside faceplate to door.
- Align the inside faceplate to door and fit mounting screws and tighten into threaded posts.
- To fix single pull handle (note: suitable for solid doors only), check that the outside faceplate is lined up straight and square with the door. Once the desired position of the outside faceplate has been confirmed, mark the centre of the hole at the top of the faceplate and proceed to drill a suitable hole.
- Note: When drilling the hole drill to a suitable depth ONLY to accommodate the coach screw
(Do not drill all the way through the door).
- On the side requiring the pull handle, hold the optional rectangular plastic washer centred over the hole against the door surface. Then hold the threaded bush onto the stainless steel, ensuring the larger section of the bush, as marked 'A' in illustration, is facing the door.
- Then, from the same side, install the 1/4" diameter coach screw through the threaded bush and optional plastic washer (if used) and into the door. Tighten coach screw securely with spanner.
- Place the two pull handle supports at each end of the pull handle over the top of the two bushes that are fitted to the door and faceplate. Line up the pull handle so that it is lined up straight and square. Insert the grub screws and tighten with allen key provided.

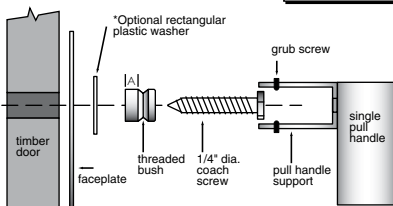
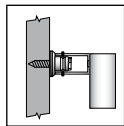

Note: Ensure larger section of threaded bush, as marked 'A' above, is facing door

FOLD HERE

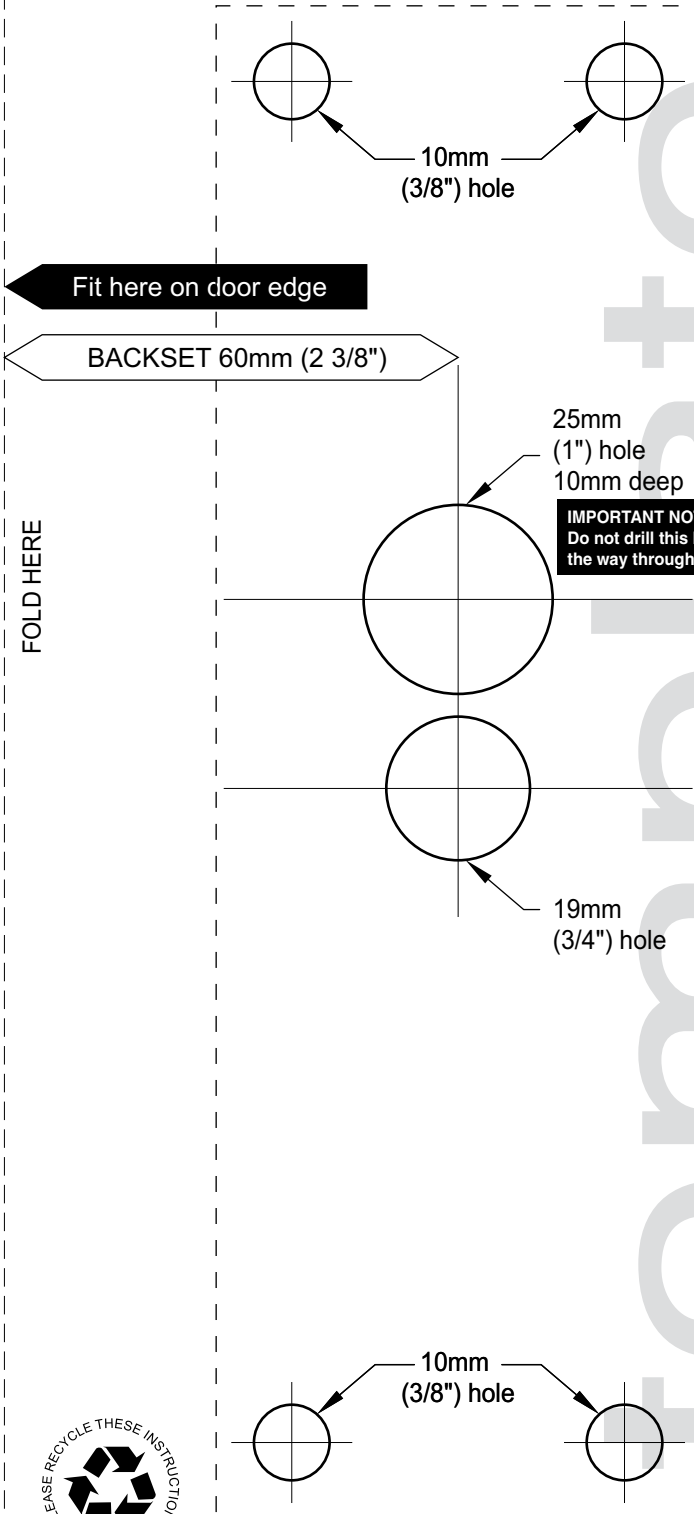

Installation template for Gainsborough Trilock Omni Dummy
Suits 35mm to 45mm door thicknesses