

Installation Instructions for 1946 Single Cylinder & 1951 Double Cylinder Deadbolts

Step 1.

- Fold template where indicated.
- Position template on door edge at desired latch height.
- Firmly hold template and mark latch height on door edge and 54mm (2 1/8") lock body hole centre.
- Measure door thickness and mark centre.
- Drill 22mm (7/8") latch hole through door edge.

Note: it is important to drill this hole squarely.
• Drill pilot hole for lock body [suggested size 3mm (1/8")]. Then enlarge hole to 54mm (2 1/8"), drilling from both sides of the door.

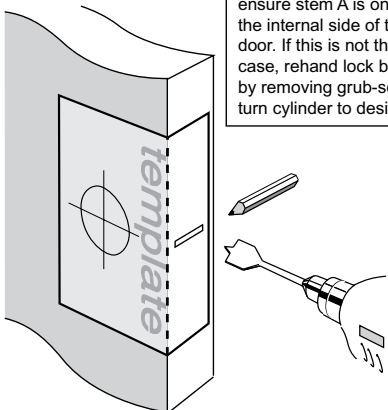

Please Note:

for a single cylinder deadbolt (ie. with internal turnbutton) ensure stem A is on the internal side of the door. If this is not the case, rehand lock body by removing grub-screw with allen key provided, turn cylinder to desired direction and re-fasten.

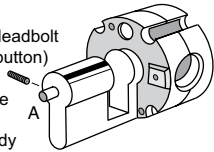

Step 2.

- Mark and chisel latch faceplate until flush with door edge. Use latch carrier as a template.
- Insert lock body into 54mm (2 1/8") hole.
- Insert bolt carrier through 22mm (7/8") hole into lock body assembly and fix with 2 screws. Ensure T-shape at rear of bolt carrier is upright.

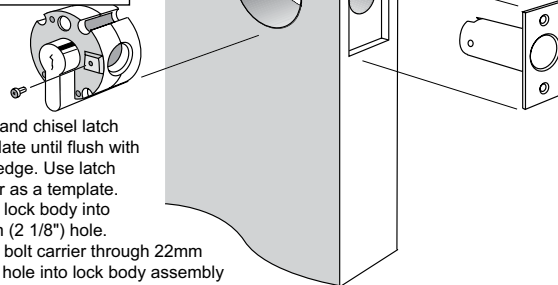

Step 3.

- Insert key and rotate towards edge of the door.
- Insert bolt until stop and rotate key away from edge of the door.
- If bolt does not operate properly repeat above steps.

- Pre-drill wood screw holes with suitable drill size.
- Install plastic faceplate shim and faceplate, then screw into position.

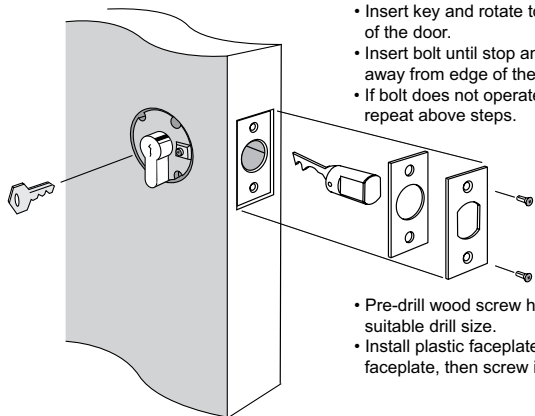

Step 4.

- Fit suitable length screws through diagonal holes on internal rosette to threaded posts on external escutcheon.
- Note:** do not overtighten screws.
- Insert key and rotate to check lock function. Please note that deadbolt requires 180° key rotation to achieve deadlocking.
- If bolt does not operate properly repeat step 3.

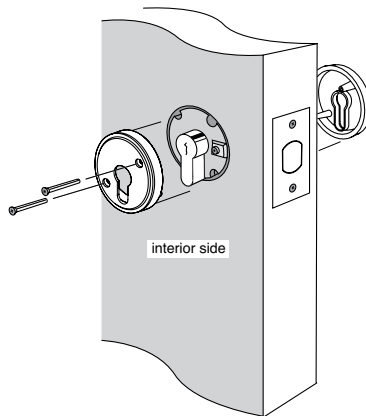

NOTE: Carefully follow these instructions when installing. Screws to be tightened to a recommended 2.5Nm torque max.



Mark centre-line of latch hole

Mark centre-line of latch hole

FOLD HERE

Fit here on door edge

Fit here on door edge

54mm (2 1/8") hole

BACKSET 60mm (2 3/8")



Installation template for 1946 single cylinder and 1951 double cylinder deadbolts

Gainsborough Hardware Industries Limited,
Melbourne, Australia. A.B.N. 25 004 792 269
www.gainsboroughhardware.com.au

PAIT 162
JAN '12



Installation Instructions for 1946 Single Cylinder & 1951 Double Cylinder Deadbolts

